



1515 WOODFIELD RD - SUITE 400

24,700 RSF

SCHAUMBURG CORPORATE CENTER

1475, 1501, 1515 E Woodfield Rd
Schaumburg, IL 60173

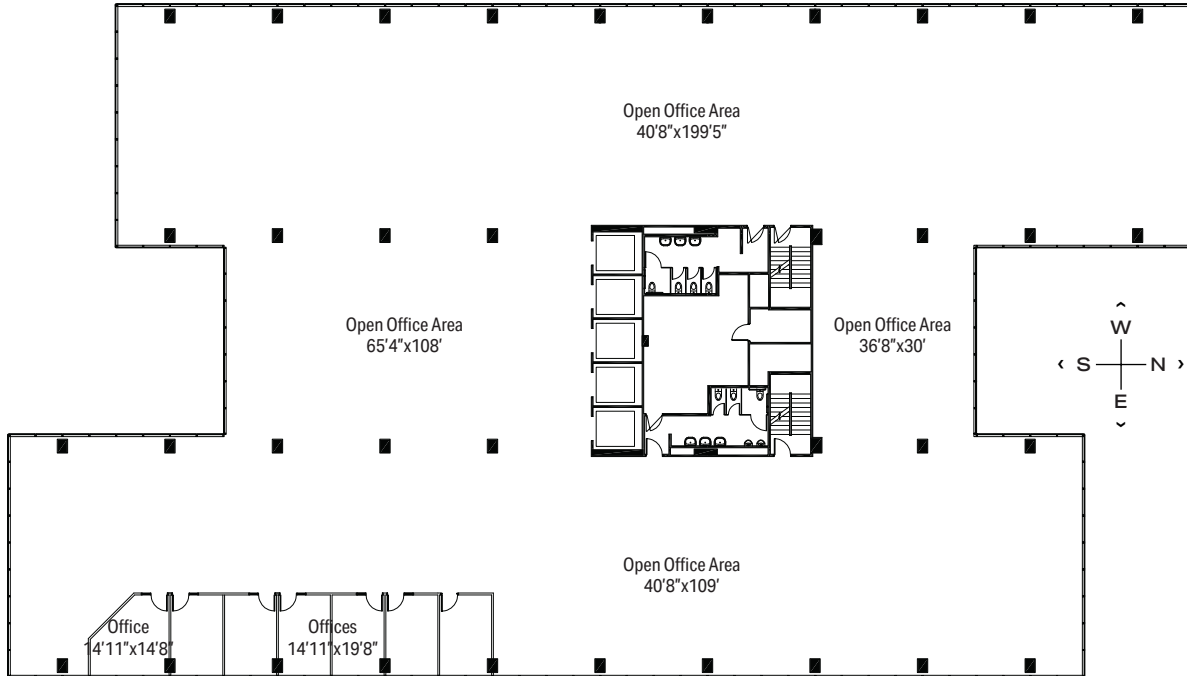

[VIRTUAL TOUR →](#)

LEASING

Dave Trumpy
Managing Director
dtrumpy@glenstar.com
773.308.1031

—

Bill Saviski
Managing Director
bsaviski@glenstar.com
773.837.5290

SchaumburgCorporateCenter.com

PROPERTY HIGHLIGHTS

- Class A amenity package including 17,000 SF atrium
- Complimentary Midtown Athletic Club membership for tenants
- Parking garage with connected pedway and heated executive parking
- Glenstar Connect Program

SUITE FEATURES

- Full floor white box suite
- Contiguous to full 5th floor totaling 49,400 RSF
- Abundant window line with exterior views on all sides
- 7 perimeter offices with exterior views
- Open office area for workstations





1515 WOODFIELD RD - SUITE 500

SCHAUMBURG CORPORATE CENTER

24,700 RSF

1475, 1501, 1515 E Woodfield Rd
Schaumburg, IL 60173

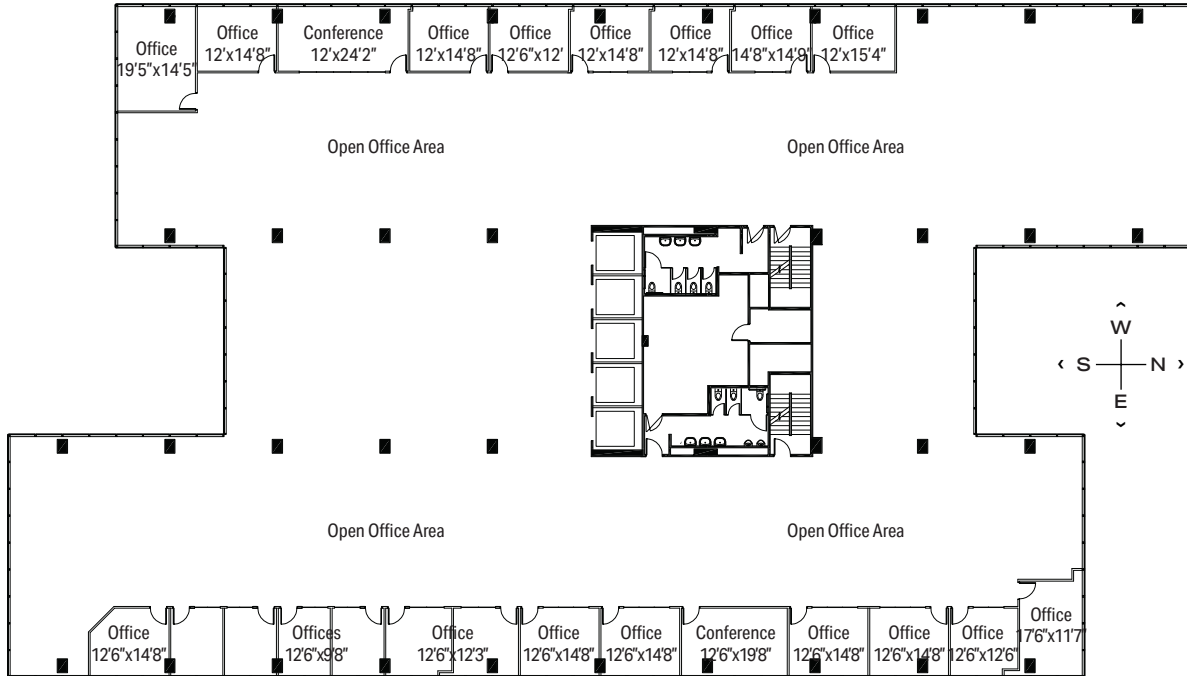

[VIRTUAL TOUR →](#)

LEASING

Dave Trumpy
Managing Director
dtrumpy@glenstar.com
773.308.1031

—

Bill Saviski
Managing Director
bsaviski@glenstar.com
773.837.5290

SchaumburgCorporateCenter.com

PROPERTY HIGHLIGHTS

- Class A amenity package including 17,000 SF atrium
- Complimentary Midtown Athletic Club membership for tenants
- Parking garage with connected pedway and heated executive parking
- Glenstar Connect Program

SUITE FEATURES

- Full floor white box suite
- Contiguous to full 4th floor totaling 49,400 RSF
- Abundant window line with exterior views on all sides
- 21 perimeter offices with exterior views
- 2 perimeter conference rooms
- Open office area for workstations





1515 WOODFIELD RD - SUITE 600

7,327 RSF

SCHAUMBURG CORPORATE CENTER

1475, 1501, 1515 E Woodfield Rd
Schaumburg, IL 60173

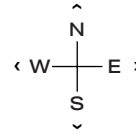
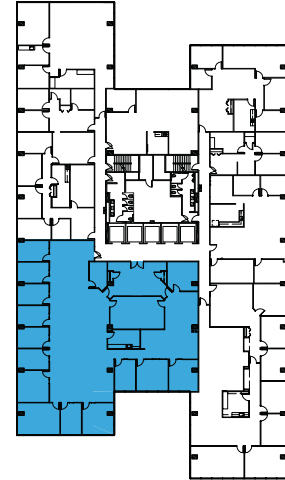
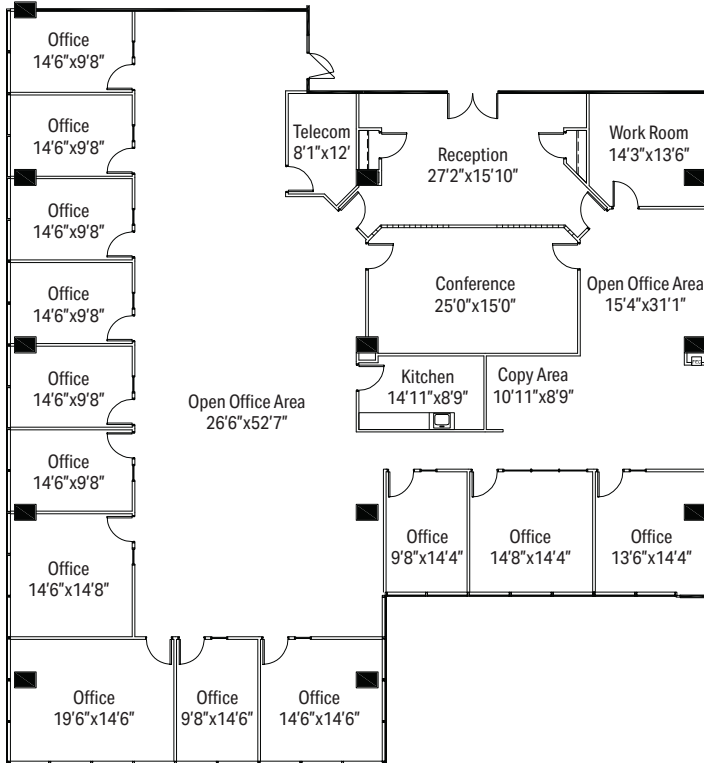

LEASING

Dave Trumpy
Managing Director
dtrumpy@glenstar.com
773.308.1031

—

Bill Saviski
Managing Director
bsaviski@glenstar.com
773.837.5290

SchaumburgCorporateCenter.com

PROPERTY HIGHLIGHTS

- Class A amenity package including 17,000 SF atrium
- Complimentary Midtown Athletic Club membership for tenants
- Parking garage with connected pedway and heated executive parking
- Glenstar Connect Program

SUITE FEATURES

- Prime elevator ID
- 13 perimeter offices, all with exterior views
- Large, open office areas for workstations
- 1 conference room
- Reception/waiting area
- Telecom and work room
- Kitchen

